

CODING EXAMPLE  
 TPS4-8"  
 ↳ NPS  
 ↳ TULSA PIPE SUPPORT SIZE

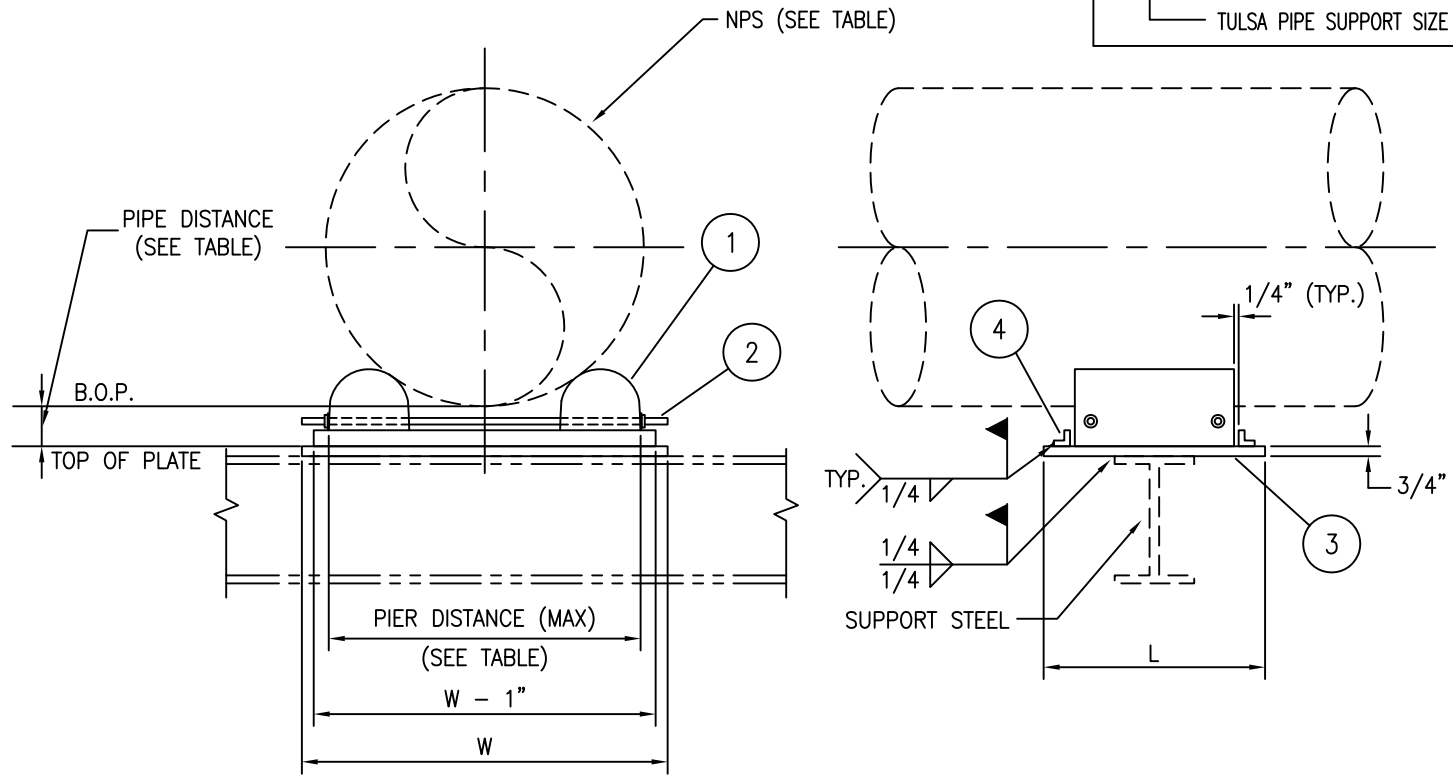

PIPE DATA		TPS SIZE	PIPE DISTANCE		TPS ROD LENGTH/DIA	PIER DISTANCE (MAX)	PLATE SIZE (L x W)
NPS SIZE	DIAMETER		MAX	MIN			
8	8.625	4	2.76	1.88	LG 13 1/4 x ø 1/2	11.79	18" x 18"
10	10.75	4	2.81	1.88	LG 14 x ø 1/2	12.47	18" x 18"
12	12.75	4	2.85	1.88	LG 14 1/2 x ø 1/2	13.05	18" x 18"
16	16	6	4.92	2.25	LG 24 1/4 x ø 1	21.61	18" x 26"
20	20	6	4.99	2.25	LG 26 x ø 1	23.16	18" x 26"
24	24	6	5.07	2.25	LG 27 1/4 x ø 1	25.25	18" x 26"

MARK No.	DESCRIPTION	No. REQ'D
1	EPOXY SUPPORT - 12" LG (TULSA SUPPLY)	2
2	ROD ALL THREAD - ZINC PLATED C/W NUTS & WASHERS (TULSA SUPPLY)	2
3	PLATE 3/4" THK. x 'L' x 'W' - CSA G40.21 GRADE 300W OR BETTER	1
4	L 2 x 2 x 1/4" - CSA G40.21 GRADE 300W	2

**NOTES:**

1. ALL SIZES AND DIMENSIONS ARE IN IMPERIAL UNITS.

0	ISSUED FOR CONSTRUCTION								
REV	REVISION	DATE	DRN	CHK	ENG	APP			
CLIENT	TITLE TULSA PIPE SUPPORT 8" TO 24" EPOXY PIPE SUPPORT TPS4/TPS6								
PREPARED BY	SCALE N.T.S.	DWG. No. SPS-0005	CLIENT DWG. No.	PROJ.	REV. 0				