

CODING EXAMPLE  
 SP2-XXXX  
 DATA SHT. No.  
 PSS STD

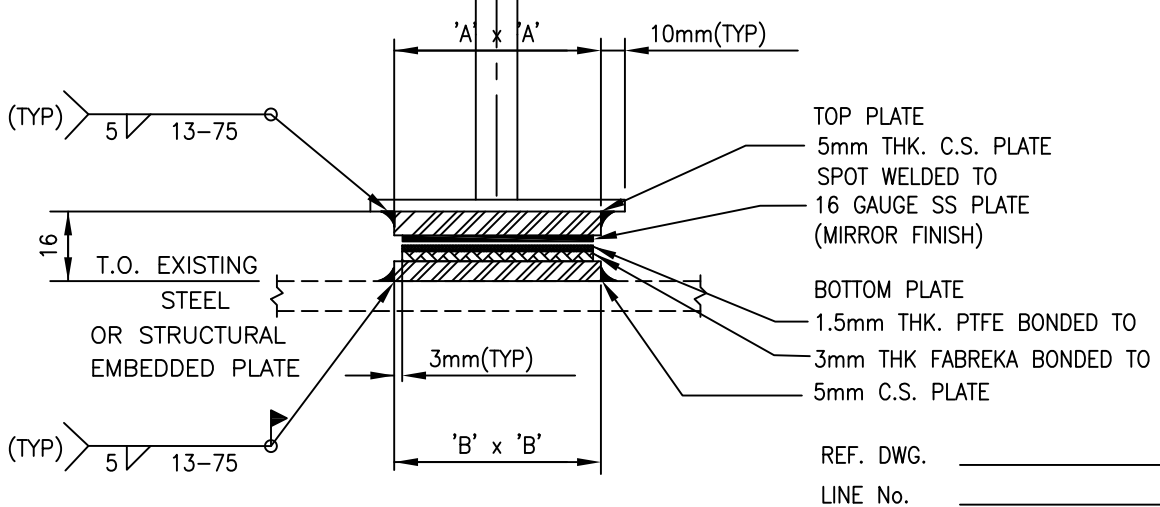
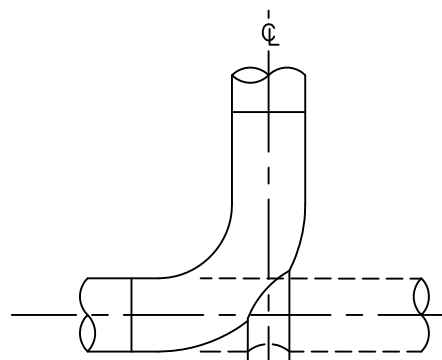

TOP PLATE  
 5mm THK. C.S. PLATE  
 SPOT WELDED TO  
 16 GAUGE SS PLATE  
 (MIRROR FINISH)

BOTTOM PLATE  
 1.5mm THK. PTFE BONDED TO  
 3mm THK FABREKA BONDED TO  
 5mm C.S. PLATE

REF. DWG. \_\_\_\_\_  
 LINE No. \_\_\_\_\_

PIPE SIZE	SLIDE PLATE ASSEMBLY SIZE ('A' SQUARE) TOP ELEMENT	SLIDE PLATE ASSEMBLY SIZE ('B' SQUARE) BOTTOM ELEMENT
2"	130	100
3"	130	100
4"	160	125
6"	200	150
8"	250	175
10"-12"	300	225
14"-16"	400	275
18"-20"	430	300
22"-24"	480	350

**NOTES:**

1. PIPING FABRICATOR TO PROTECT SS MIRROR FINISH FROM DAMAGE AND TEMPORARILY ATTACH THE MATING BOTTOM PLATE TO THE BASE SUPPORT FOR SHIPPING
2. AVOID WELD SPLATTER AND WIPE CONTACT SURFACES CLEAN OF LOOSE PARTICLES BEFORE INSTALLATION OF LINE.

0	ISSUED FOR CONSTRUCTION						
REV	REVISION	DATE	DRN	CHK	ENG	APP	

CLIENT	TITLE DATA SHEET TEFLON SLIDE PLATE ASSEMBLY FOR BASE SUPPORTS SP2					
PREPARED BY	SCALE N.T.S.	DWG. No. SP02 - XXXX	PROJ.	REV. 0		
		CLIENT DWG. No.				